

8mil BGA PCB / HDI PCB / PCB

PCB : PCB / 8mil BGA / HDI PCB / HDI PCB (HDI PCB)



----- PRODUCT DESCRIPTION -----

TOP QUALITY PCBA

O-LEADING
To Be **Reliable**, To Be **Valuable**

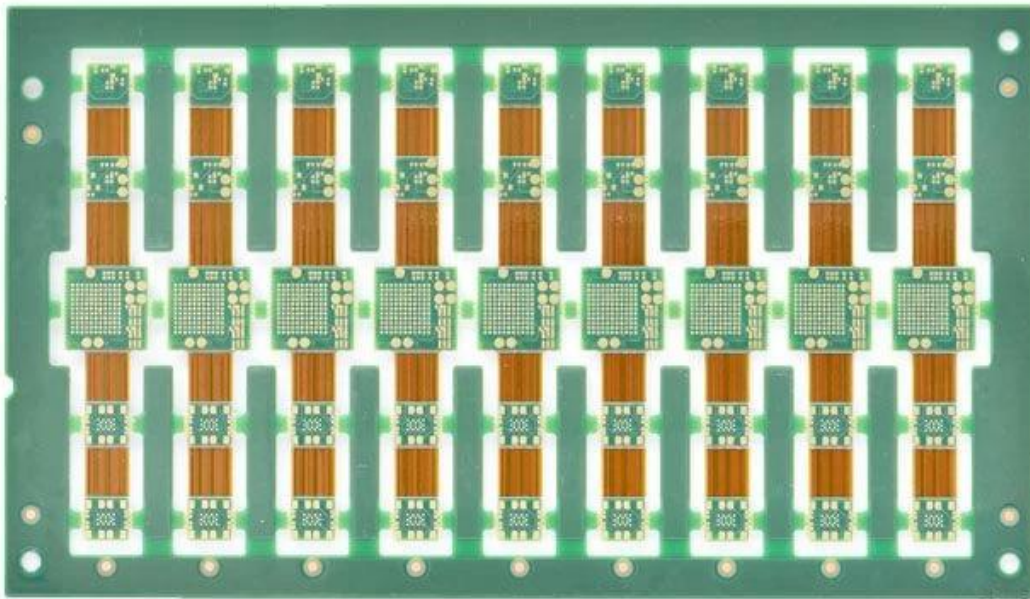

Multilayer HDI PCB

TOP QUALITY PCBA

O-LEADING

To Be **Reliable**, To Be **Valuable**

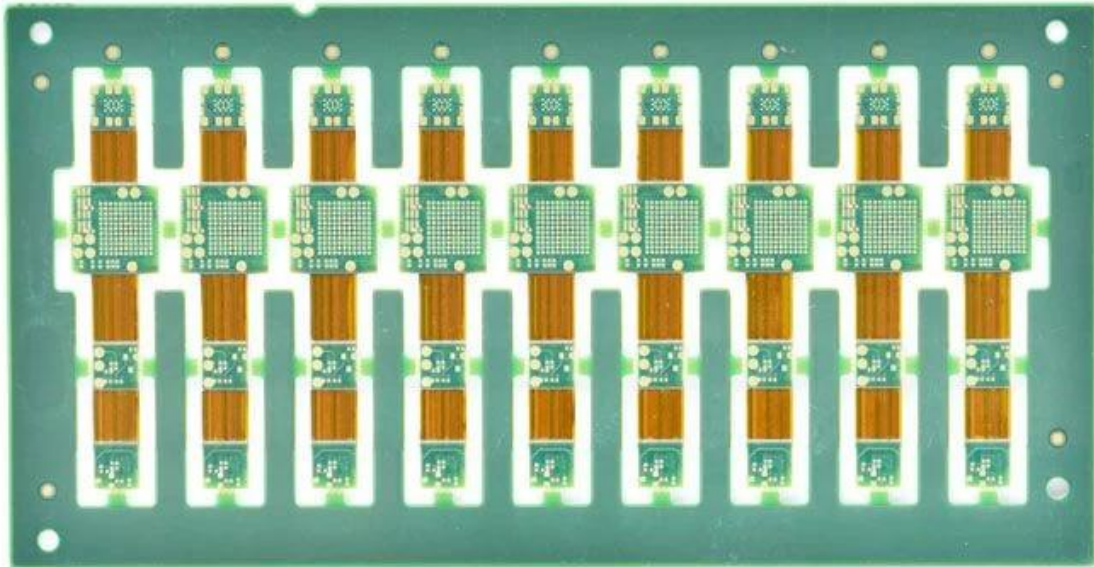

8mil BGA PAD TRUE

TOP QUALITY PCBA

O-LEADING

To Be Reliable, To Be Valuable

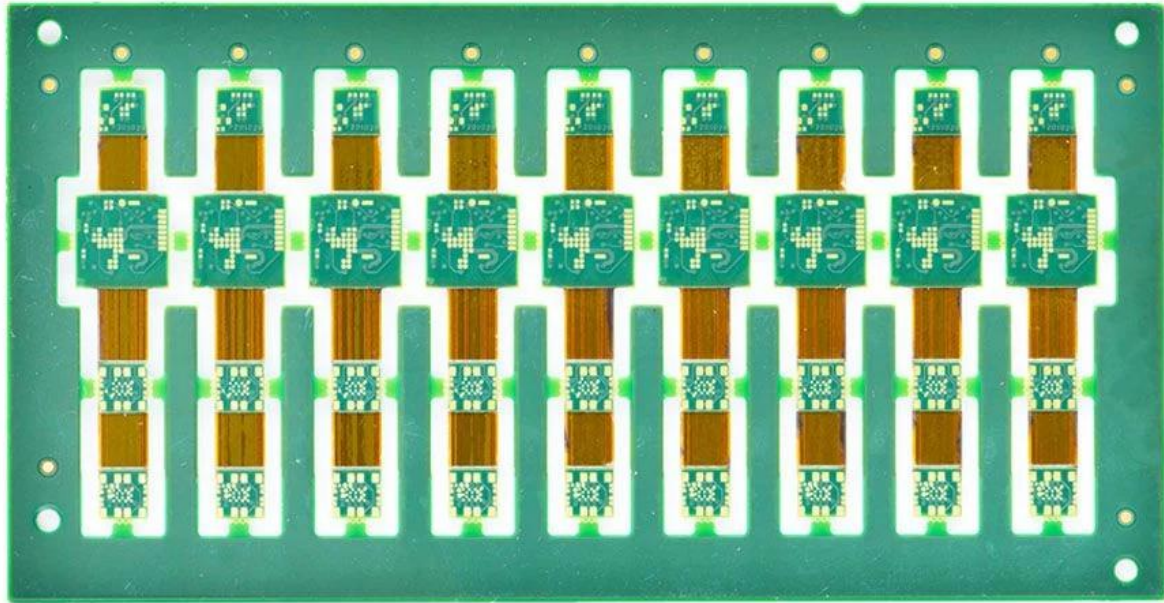

Quick turn HDI PCB

TOP QUALITY PCBA

O-LEADING
To Be Reliable, To Be Valuable

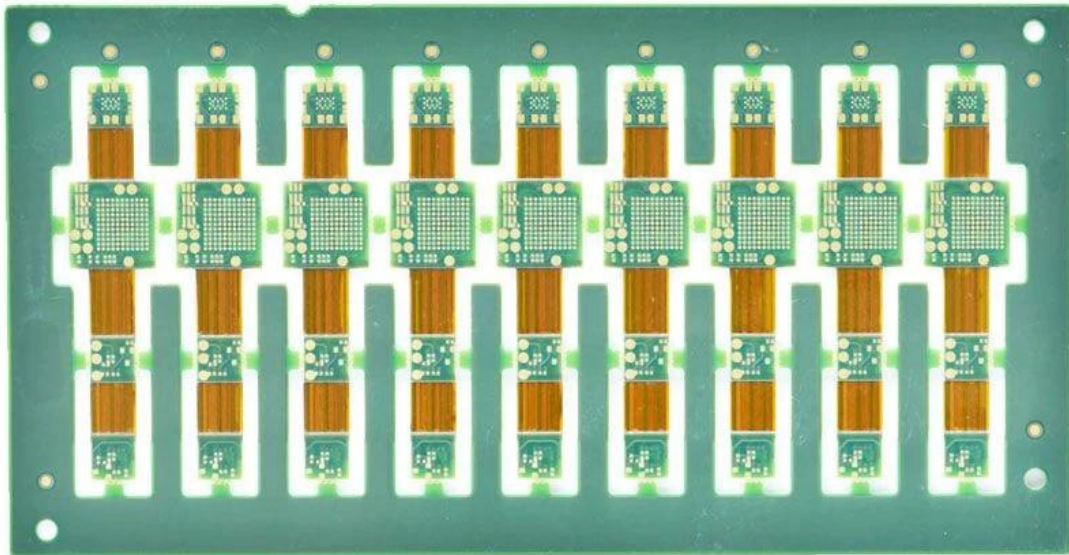

HDI PCB with blind via holes and buried via holes

TOP QUALITY PCBA

O-LEADING
To Be Reliable, To Be Valuable



VOP Comparison

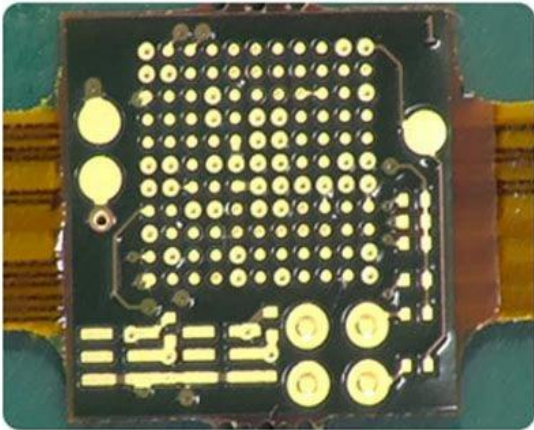

Other competitors is dent in the Pad.

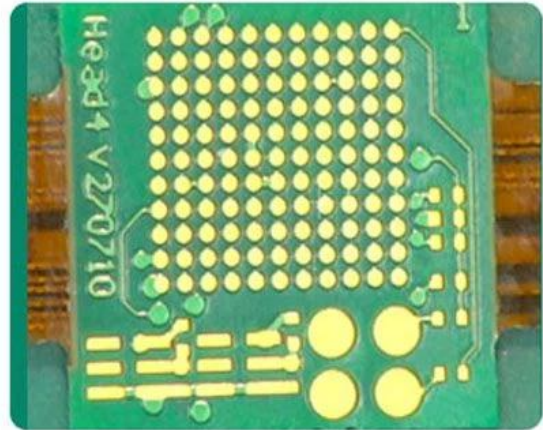

Our PCB is flat.

MAKE YOUR IDEA COME TRUE

TOP QUALITY PCBA

O-LEADING

To Be Reliable, To Be Valuable



Layer	Stack up	Processed Thickness	Supplier Description	Copper Coverage	Impedance ID	Isolation Distance (Summed)
1		50,000	PROBIMER77			
		45,000	CSC_0.49_12/12_HTE_Punched	0,000		141,400
		58,200	106_38N_Polyimide_No_flow			-
		58,200	106_38N_Polyimide_No_flow			-
2		25,000	LF7001			-
		9,000	KK_0.025_9_9_Du_AP7163E	60,000		25,000
		25,000	LF7001			192,800
		9,000	KK_0.025_9_9_Du_AP7163E	60,000		-
3		25,000	LF7001			-
		71,400	1080_38N_Polyimide_No_flow			-
		71,400	1080_38N_Polyimide_No_flow			-
		25,000	LF7001			-
4		9,000	KK_0.025_9_9_Du_AP7163E	60,000		25,000
		25,000	LF7001			141,400
		58,200	106_38N_Polyimide_No_flow			-
		58,200	106_38N_Polyimide_No_flow			-
5		45,000	CSC_0.49_12/12_HTE_Punched	0,000		-
		50,000	PROBIMER77			

Copper Thickness = 126,000 | Dielectric Thickness = 525,600 | Solder Mask Thickness = 100,000 |
Stack Up Thickness = 651,600 | Stack Up Thickness with Soldermask = 751,600

Drill Image	1st Layer	2nd Layer	Column Position	Drill Type	Fill Type
	1	2	2	Laser PTH	None
	1	6	1	Mechanical PTH	None
	6	5	2	Laser PTH	None

MAKE YOUR IDEA COME TRUE

Query All

Type:	Flash
At:	1065.4:1088.6
Type:	Thru Hole
Net:	
Layer:	L14:Head4.GTL
Layer Type:	Graphic
Dcode:	D77
Shape:	Round
Size:	8.2

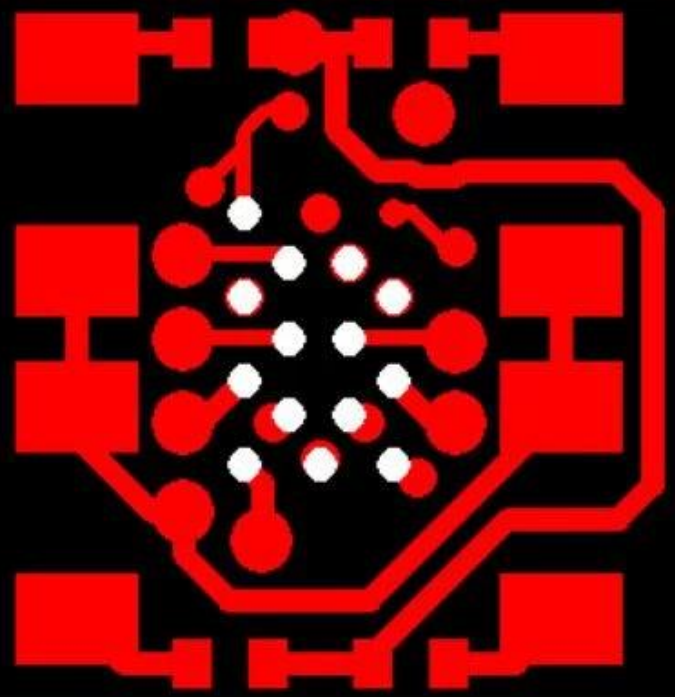

Production Process

18 years experience in one-stop PCB and PCBA, we can make your idea come true,



品质至上
Quality Focused



用户满意
Customer satisfaction

永续经营
Exemplary management

Process flow chart

工艺能力 Process Capability

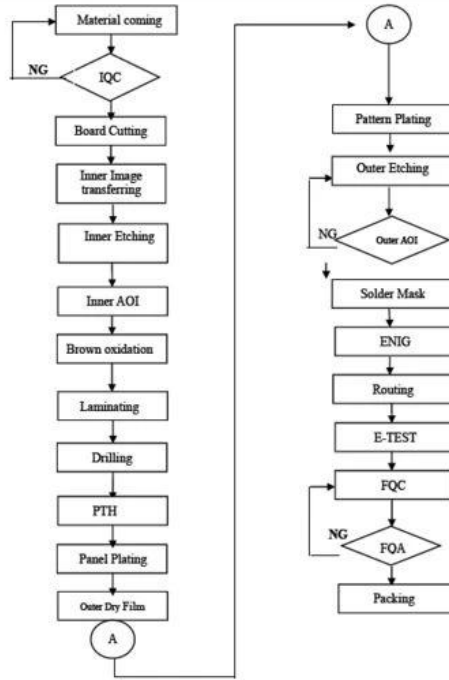

● ● ● ● ●
APPLICATION

 Engineering	 PCB CAD Layout	 Materials	 Electro-Mechanical Assembly	 Printed Circuit Board Assembly	 Test Solutions	 System Build	 BGA & Board Repair
-----------------	--------------------	---------------	---------------------------------	------------------------------------	--------------------	------------------	------------------------



WHY CHOOSE US?



TO BE
RELIABLE



Quality first,
Customer supreme,
Scientific management,
Striving for famous brand



TO BE
VALUABLE



Science and technology
keeps head,
Put people first,
Be precise and practical,
Contribute sincerely



KEEP
LEADING



There's a phrase in Buddhism,
'Beginner's mind.'

It's wonderful to have a
beginner's mind.



COMPANY PROFILE



O-Leading strives to be your one stop solution partner in EMS supply chain, including PCB design, PCB fabrication and PCB assembly (PCBA). We provide some of the most advanced PCB technology, including HDI PCBs, multilayer PCBs, Rigid-Flexible PCBs. We can support from quick turn prototype to medium & mass Production. In general, our global customers are very impressed with our services: rapid response, competitive price and quality commitment. Providing more valuable technical service and overall solution is the way O-leading forward.



SGS

SGS

SGS



Looking to the future, O-leading will concentrate on the innovation and development of electronics manufacturing technology as always, and make persistent efforts on PCB & PCBA one-stop service to provide first-class services and create more value for our customers. PCB Assembly manufacturer china.





PROCESS CAPABILITY

PCB	
Layer	1Layer-32layer.
Weight	1 / 3oz-12oz.
Thickness	3.0mil / 3.0mil.
Thickness Tolerance	4.0mil / 4.0mil.
Aspect Ratio	10 : 1.
Thickness	0.2mm-5.0mm.
Size (mm)	635 * 1500mm.
Surface Finish	4mil.
Surface Finish Tolerance	+/- 3mil.
BIIND / (AI)	
VIA (Micro, Macro)	
Material	fr-4, fr-4high tg.halogen, FR-5, FR-4, FR-408, FR-406, FR-403, FR-401
Plating	HASL, OSP, ENIG, HAL-LF, LMMersion, Immersion tin, Electroless Ni, Electroless Cu
SMT	
PCB	FR-4, CEM-1, CEM-3, FR-5, FR-4, FPC
PCB Size	510x1500mm.
PCB Size	50x50mm.
PCB Thickness	0.5mm-4.5mm.
Drill Diameter	0.5-4mm.
Drill Diameter	0201.
Drill Diameter	0603
Drill Diameter	15mm
Drill Diameter	0.3mm.
Drill Diameter BGA	0.4mm.
Drill Diameter	+/- 0.03mm.

OUR EXHIBITION



PRODUCTION PROCESS

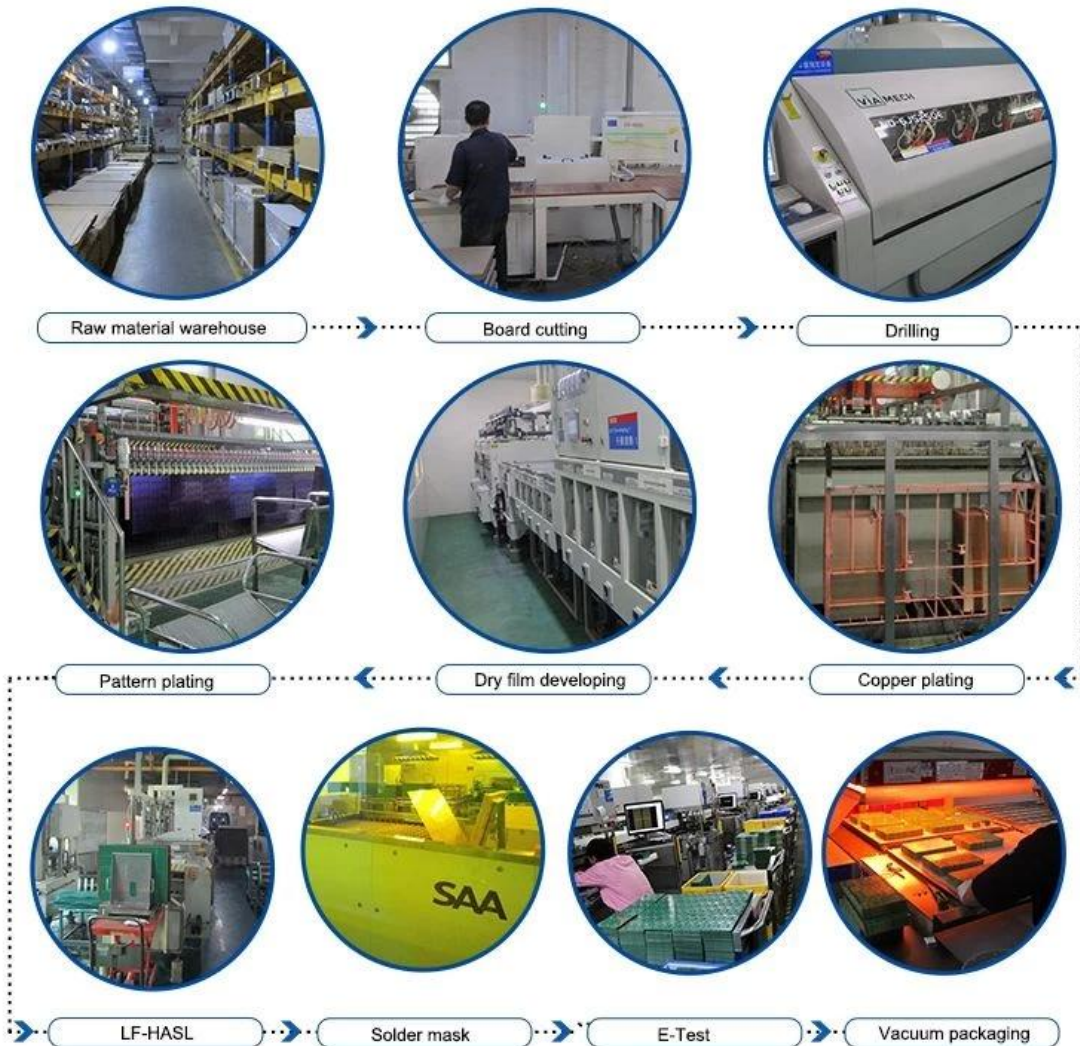



PRODUCTION LINE

PCB PRODUCTION WORKSHOP



AUTOMATIC VACUUM PRESS MACHIN



DRILLING MA CHINE



PATTERN PLATING MACHINE



SCRUBBING MACHINE



DEVELOPING MACHINE



ROUTING MACHINE

SMT PRODUCTION WORKSHOP



OUR CUSTOMER REVIEWS



<p>订单编号: 49335463501024670</p> <p>供应商服务: 非常满意 (5 stars) 按时发货: 非常满意 (5 stars)</p> <p>High quality usb power pcb , pcba manufacturer ★★★★★ Fancy has done an excellent job, whenever we write, she answered us within 1 second, O-leading is very perfect with fast delivery, fast logistics, the most important thing is good quality, good packaging, thank you!</p> <p>回复该评论</p> <p>oem customized rohs pcb drawing schematic s... ★★★★★ We received the boards, the quality is very good, the price is very reasonable, Fancy is very nice & smart & experienced, the logistics is super fast, I will come to see more in the future.</p> <p>回复该评论</p>	<p>订单编号: 4902411001024670</p> <p>供应商服务: 非常满意 (5 stars) 按时发货: 非常满意 (5 stars)</p> <p>High TG180 FR-4 Circuit HDI PCB 94V0 Board ... ★★★★★ This is a very difficult PCB design, but we are lucky to find O-leading to support the PCB for us, very good to go PCB supplier!</p> <p>universal FR4 Multilayer PCB washing machine... ★★★★★ Fancy gives us very excellent service, very professional and experienced, O-leading is the best one of our suppliers, very happy to work with them.</p>
<p>订单编号: 49298271001024670</p> <p>供应商服务: 非常满意 (5 stars) 按时发货: 非常满意 (5 stars)</p> <p>High TG180 FR-4 Circuit HDI PCB 94V0 Board ... ★★★★★ perfect product, perfect PCB supplier!</p> <p>回复该评论</p> <p>oem customized rohs pcb drawing schematic s... ★★★★★ Very good and professional PCB product as usual!</p> <p>回复该评论</p> <p>Strip LED Aluminum FR-4 lighting PCB board 9... ★★★★★ High quality, fast delivery, good service, competitive price, lucky and happy to purchase from O-leading!</p> <p>回复该评论</p>	<p>订单编号: 49024962001024670</p> <p>供应商服务: 非常满意 (5 stars) 按时发货: 非常满意 (5 stars)</p> <p>High quality Keyboard pcb & pcba Factory SMT... ★★★★★ Top quality, it's the right choice to choose O-leading to make the PCB & PCBA</p> <p>回复该评论</p> <p>订单编号: 40938632501024670</p> <p>供应商服务: 非常满意 (5 stars) 按时发货: 非常满意 (5 stars)</p> <p>Professional Printed Circuit Board Manufactur... ★★★★★ Very high quality PCB products, O-leading is the best PCB supplier that we have ever worked with.</p> <p>订单编号: 44066794501024670</p> <p>供应商服务: 非常满意 (5 stars) 按时发货: 非常满意 (5 stars)</p> <p>High TG180 FR-4 Circuit HDI PCB 94V0 Board ... ★★★★★ We bought two batches, one by DHL, the other one by air, good quality and fast delivery!</p>

LISTEN TO CUSTOMER VOICE

订单编号: 40903347501024670

供应商服务: 非常满意 (5 stars) 按时发货: 非常满意 (5 stars)



Strip LED Aluminum FR-4 lighting PCB board 9...

★★★★★
Very fast delivery! Fantastic, good job!!



Professional Printed Circuit Board Manufactur...

★★★★★
Very happy to great support from O-leading,they are not only professional on the PCB, but also provide good PCB products, very good supplier!!



hot sale rigid-flexible PCB with 0.2mm BGA an...

★★★★★
very professional supplier.



High Quality custom FPCB/Flex PCB/FPC/Flexi...

★★★★★
Good product



OEM ODM PCBA Bluetooth Wireless Marking G...

★★★★★
high soldering quality



Electronic parts haptic pcba Circuit Board asse...

★★★★★
Very Good product

订单编号: 37378603001024670

供应商服务: 非常满意 (5 stars) 按时发货: 非常满意 (5 stars)



Raspberry pi 0 Zero Raspberry Pi Zero Pi W ver...

★★★★★
Fantastic products!!



double layer pcb with red S/M and LF-HASL su...

★★★★★
Good!

订单编号: 36919647001024670

供应商服务: 非常满意 (5 stars) 按时发货: 非常满意 (5 stars)



AML-S802 Quad-core Android embedded boar...

★★★★★
Good products



Fast delivery low cost pcb fabrication O-leadi...

★★★★★
Good supplier



Lidar IR Sensor board pcba(H08R6x)

★★★★★
perfect product



Customized PCBA design PCB design

★★★★★
perfect



Audio Speaker and Headphone Jack (H07R3x)

★★★★★
High quality, good



half hole pcb, half hole pcb module, half hole m...

★★★★★
Top half hole pcb supplier, very perfect goods



High Quality custom FPCB/Flex PCB/FPC/Flexi...

★★★★★
this rigid-flexible pcb quality is perfect!



Electronic parts haptic pcba Circuit Board asse...

★★★★★
Very satisfied with O-leading products and quality,especially their on-time delivery, fantastic!

Be **kind** to your client,
because he has many choices,
but he chooses you instead.

