

Bienvenue chez O-Leading

O-Leading s'efforce d'être votre partenaire unique dans la chaîne d'approvisionnement EMS, y compris la conception de circuits imprimés, la fabrication de circuits imprimés et l'assemblage de circuits imprimés, nous fournissons certaines des technologies de circuits imprimés les plus avancées, y compris les circuits imprimés HDI, les circuits imprimés multicouches, les circuits imprimés rigides et flexibles. prise en charge du prototype à rotation rapide à la production de moyenne et de masse.

En général, nos clients mondiaux sont très impressionnés par nos services: réponse rapide, prix compétitifs et engagement de qualité.

Tourné vers l'avenir, O-Leading se concentrera sur l'innovation et le développement de la technologie de fabrication électronique, comme toujours, et fera des efforts persistants sur le service à guichet unique PCB et PCBA pour fournir des services de première classe et créer plus de valeur pour nos clients.

VEUILLEZ CLIQUER ICI POUR PLUS D'INFORMATIONS [Usine d'assemblage de circuits imprimés électroniques](#)

O-LEADING
To Be Reliable, To Be Valuable

WE ALWAYS PROVIDE YOU

BEST HIGH DENSITY INTERCONNECT PCB

WE ALWAYS PROVIDE YOU

BEST RIGID-FLEXIBLE CIRCUIT

Description du produit

Raspberry Pi 3 modèle A +, avec la plupart des améliorations comme Raspberry Pi 3B +, dans un facteur de forme plus petit et un prix inférieur ([Fournisseur professionnel de circuits imprimés flexibles rigides pour Raspberry Pi](#))

Aperçu

En réduisant de moitié la RAM à 512 Mo et en supprimant le concentrateur USB et le contrôleur Ethernet, le Raspberry Pi 3 Model A + est capable de devenir plus petit en taille, et a atteint un prix inférieur.

Le Raspberry Pi 3 Model A + intègre la plupart des améliorations intéressantes comme son grand frère Raspberry Pi 3B +, et comprend:

- * Un processeur ARM Cortex-A53 quadricœur 64 bits à 1,4 GHz
- * 512 Mo de mémoire SDRAM LPDDR2
- * LAN sans fil 802.11ac bi-bande et Bluetooth 4.2 / BLE
- * Amélioration du démarrage du stockage de masse USB
- * Gestion thermique améliorée

Comme son grand frère, la carte entière est certifiée en tant que module radio selon les règles de la FCC, ce qui réduira considérablement le coût des tests de conformité des produits à base de Raspberry Pi.

TOP QUALITY PCBA

O-LEADING

To Be Reliable, To Be Valuable



MAKE YOUR IDEA COME TRUE

Caractéristiques

- * Broadcom BCM2837B0, Cortex-A53 (ARMv8) SoC 64 bits à 1,4 GHz
- * 512 Mo de mémoire SDRAM LPDDR2
- * LAN sans fil IEEE 802.11.b / g / n / ac 2,4 GHz et 5 GHz, Bluetooth 4.2 / BLE
- * Pas de port Ethernet
- * En-tête GPIO 40 broches étendu
- * HDMI pleine taille
- * Un seul port USB 2.0
- * Port de caméra CSI pour connecter un module de caméra Raspberry Pi
- * Port d'affichage DSI pour connecter un écran tactile Raspberry Pi
- * Sortie stéréo 4 pôles et port vidéo composite
- * Port Micro SD pour charger votre système d'exploitation et stocker des données
- * Entrée d'alimentation CC 5 V / 2,5 A

TOP QUALITY PCBA

O-LEADING
To Be **Reliable**, To Be **Valuable**



MAKE YOUR IDEA COME **TRUE**

TOP QUALITY PCBA

O-LEADING
To Be **Reliable**, To Be **Valuable**



MAKE YOUR IDEA COME **TRUE**

TOP QUALITY PCBA

O-LEADING
To Be Reliable, To Be Valuable

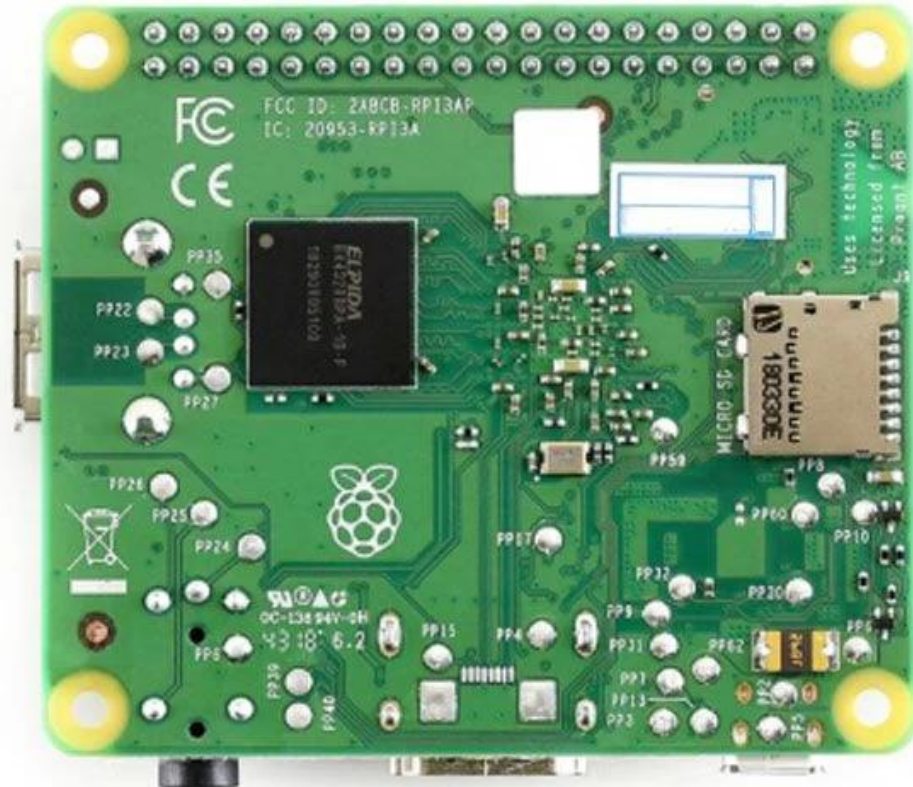

MAKE YOUR IDEA COME **TRUE**

TOP QUALITY PCBA

O-LEADING
To Be Reliable, To Be Valuable

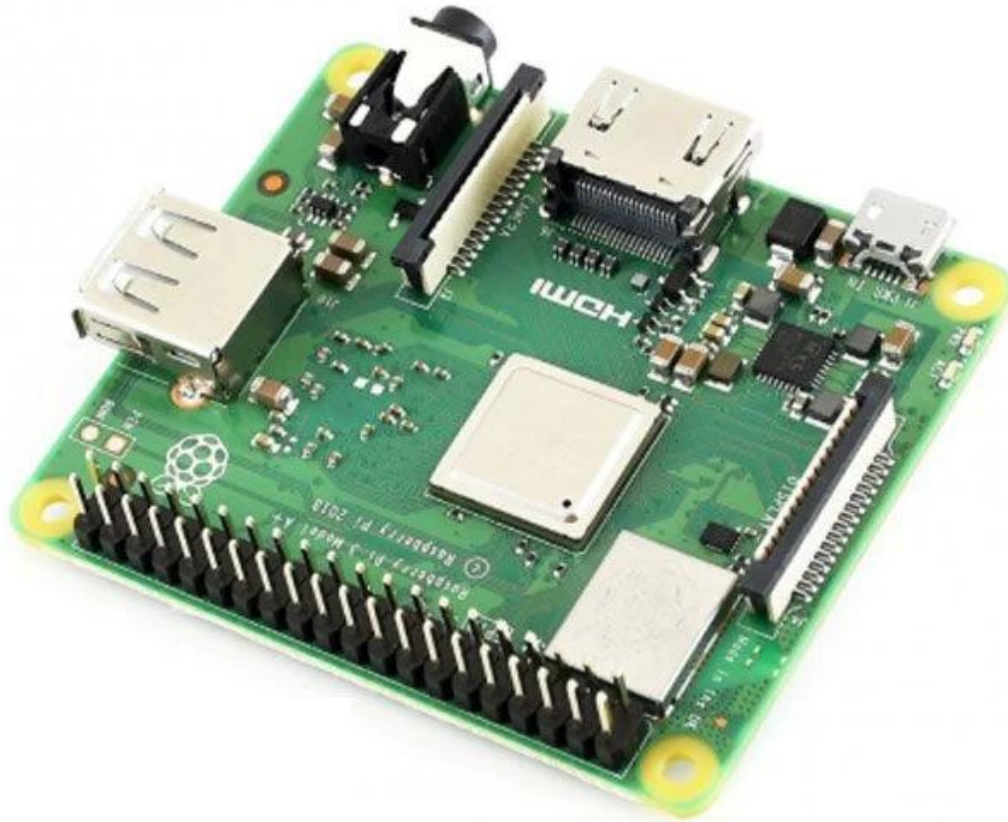

MAKE YOUR IDEA COME **TRUE**

Notre équipe

O-LEADING CUSTOMER

To be **RELIABLE**

- Q**uality first ,
- C**ustomer supreme ,
- S**cientifically management ,
- S**triving for famous brand



THE CUSTOMER IS KING

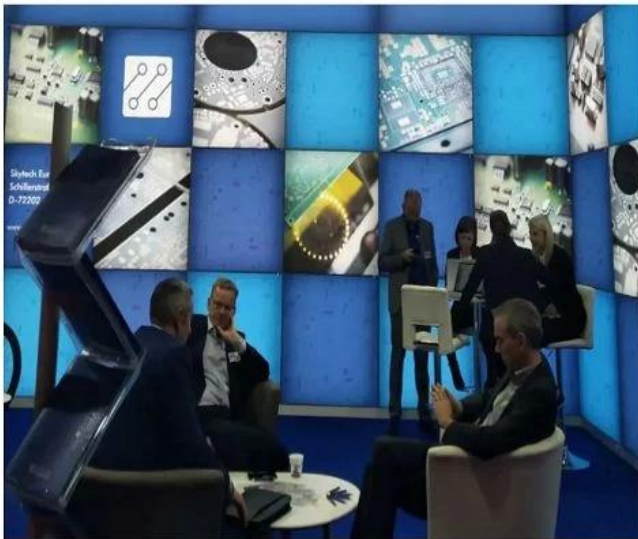

To be **VALUABLE**

- S**cience and technology keeps head ,
- P**ut people first ,
- B**e precise and practical ,
- C**ontribute sincerely

Factory PCB



Automatic vacuum press machine



Drilling Machine



Pattern Plating Machine



Scrubbing Machine



Developing Machine



Routing Machine



High-speed flying probe machine



E-test Machine

Factory SMT



HOW O-LEADING MAKE A PROJECT FOR YOU

Hardware Dispenser Application Not

Automatic Dispenser Application Not

Voltage Table

Volt Pin Number	Description
VDD	Battery voltage
+3V3	+3.3V
+5V	+5V
USB +5V	USB 5V input
+5V/2	Isolated +5V
+12V	12V DC Drive

STM32F072 PINOUT table

Wire Name	Description	DIO	Mode	Note
SMTN_TOF	Shutdown Time of flight sensor	Output		Logic '0' to shutdown
I2C_SCL_TOF	I2C communication with time of flight sensor	I2C1_SCL		
I2C_SDA_TOF	I2C communication with thermopile sensor	I2C1_SDA		
I2C_SCL_IR	I2C communication with thermopile sensor	I2C2_SCL		
I2C_SDA_IR	I2C communication with thermopile sensor	I2C2_SDA		
RATE_LC	Load cell control pins	Output		
DOUT_LC	Load cell control pins	Output		

O-LEADING
TO BE RELIABLE, TO BE AVAILABLE

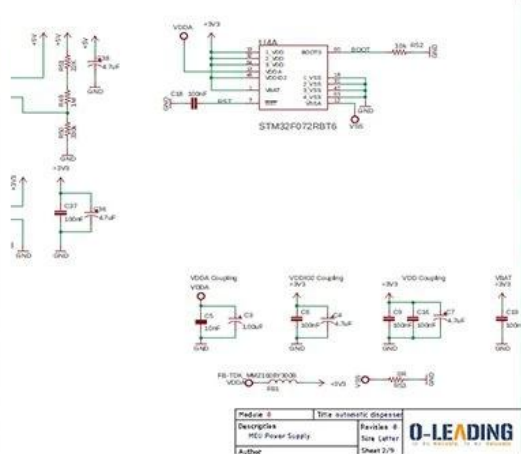

HARDWARE schematics

PCB PRODUCTION COMPONENTS SOURCING

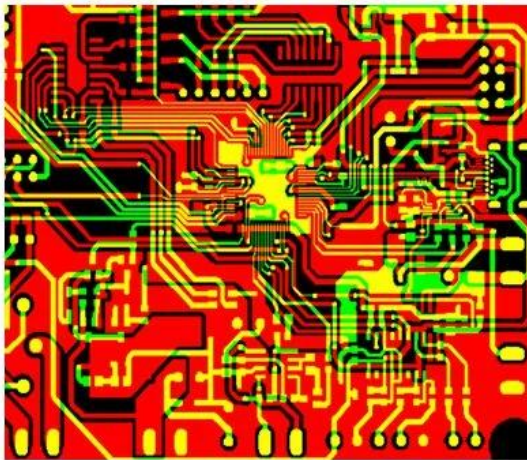

Qty	Value	Device	Parts	Description
4	AK500/2	AK500/2	X1, X2	CONNECTOR
1	AK500/3	AK500/3	X7	CONNECTOR
1	1241148	MA04-2	SV2	
1	PPPC04	MA04-2	SV1	8 POS, 4*2 FEMALE PIN HEAD
1	ML10	ML10	SV4	HARTING
1	8MHZ	XTALL_CSTCE8M	X5	STCE8M00G52-R0 RESONATOR
1	0R	R-0603	R53	Thick Film Resistors - SMD 0603
2	10R	R-0603	R12, R5	Thick Film Resistors - SMD 0603
8	100R	R-0603	R1, R2	Thick Film Resistors - SMD 0603
1	270R	R-0805	R15	Thick Film Resistors - SMD 0605
1	330R	R-0603	R11	Thick Film Resistors - SMD 0603
9	680R	R-0603	R20, R3	Thick Film Resistors - SMD 0603
17	1k	R-0603	R9, R10	Thick Film Resistors - SMD 0603
2	4.7k	R-0603	R17, R6	Thick Film Resistors - SMD 0603
2	5.1k	R-0603	R18, R1	Thick Film Resistors - SMD 0603
9	10k	R-0603	R16, R3	Thick Film Resistors - SMD 0603

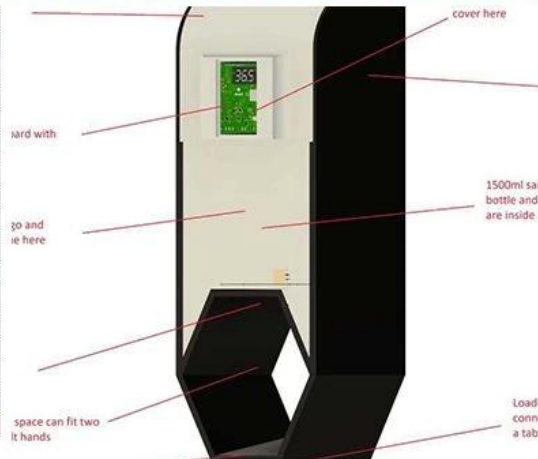
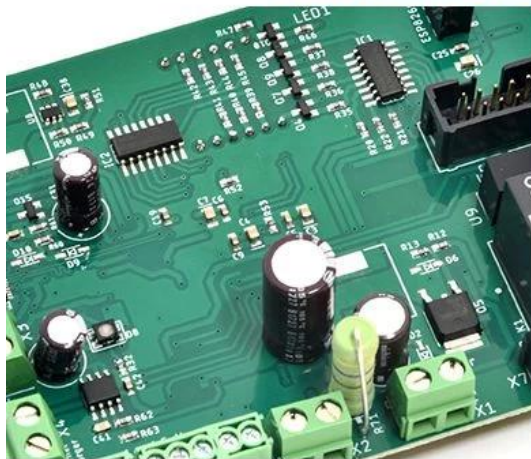

PCB Assembly MECHANICAL DESIGN

Skyworth 创维

HET 和而泰
HET INTELLIGENT CONTROL

dongweikeji
东威科技

美的 Midea

STAR-NET
星网锐捷

FORYOU
ADAYO 华阳集团

EDIFIER[®]

Cultraview 金锐显

3nod 三诺

T&W

TCL

AcBel 康舒科技
ACBEL POLYTECH INC.

Honeywell

Schneider
Electric

ZTE 中兴

EMERSON

BYD

PHILIPS

TE
connectivity

VIDEOTON

CUSTOMER VOICE IS **EXTREMELY IMPORTANT** TO US

<p>订单编号: 49335463501024670</p> <p>供应商服务: 非常满意 (5 stars) 按时发货: 非常满意 (5 stars)</p> <p>High quality usb power pcb , pcba manufacturer ★★★★★ Fancy has done an excellent job, whenever we write, she answered us within 1 second, O-leading is very perfect with fast delivery, fast logistics, the most important thing is good quality, good packaging, thank you!</p> <p>回复该评论</p> <p>oem customized rohs pcb drawing schematic s... ★★★★★ We received the boards, the quality is very good, the price is very reasonable, Fancy is very nice & smart & experienced, the logistics is super fast, I will come to see more in the future.</p> <p>回复该评论</p>	<p>订单编号: 49922411001024670</p> <p>供应商服务: 非常满意 (5 stars) 按时发货: 非常满意 (5 stars)</p> <p>High TG180 FR-4 Circuit HDI PCB 94V0 Board... ★★★★★ This is a very difficult PCB design, but we are lucky to find O-leading to support the PCB for us very good to a PCB supplier.</p> <p>universal FR4 Multilayer PCB washing machine... ★★★★★ Fancy gives us very excellent service, very professional and experienced, O-leading is the best one of our suppliers, very happy to work with them.</p>
<p>订单编号: 49298271001024670</p> <p>供应商服务: 非常满意 (5 stars) 按时发货: 非常满意 (5 stars)</p> <p>High TG180 FR-4 Circuit HDI PCB 94V0 Board ... ★★★★★ perfect product, perfect PCB supplier!</p> <p>回复该评论</p> <p>oem customized rohs pcb drawing schematic s... ★★★★★ Very good and professional PCB product as usual!</p> <p>回复该评论</p> <p>Strip LED Aluminum FR-4 lighting PCB board 9... ★★★★★ High quality, fast delivery, good service, competitive price, lucky and happy to purchase from O-leading!</p> <p>回复该评论</p>	<p>订单编号: 49024962001024670</p> <p>United States 供应商服务: 非常满意 (5 stars) 按时发货: 非常满意 (5 stars)</p> <p>High quality Keyboard pcb & pcba Factory SMT... ★★★★★ Top quality, it's the right choice to choose O-leading to make the PCB & PCBA</p> <p>回复该评论</p>
	<p>订单编号: 499862201024670</p> <p>供应商服务: 非常满意 (5 stars) 按时发货: 非常满意 (5 stars)</p> <p>Professional Printed Circuit Board Manufactur... ★★★★★ Very high quality PCB products, O-leading is the best PCB supplier that we have ever worked with.</p>
	<p>订单编号: 44068794501034670</p> <p>供应商服务: 非常满意 (5 stars) 按时发货: 非常满意 (5 stars)</p> <p>High TG180 FR-4 Circuit HDI PCB 94V0 Board ... ★★★★★ We bought two batches, one by DHL, the other one by air, good quality and fast delivery!</p>

LISTEN TO **CUSTOMER VOICE**

<p>订单编号: 40903347501024670</p> <p>供应商服务: 非常满意 (5 stars) 按时发货: 非常满意 (5 stars)</p> <p>Strip LED Aluminum FR-4 lighting PCB board 9... ★★★★★ Very fast delivery! Fantastic, good job!!!</p> <p>Professional Printed Circuit Board Manufactur... ★★★★★ Very happy to great support from O-leading, they are not only professional on the PCB, but also provide good PCB products, very good supplier!</p>	<p>订单编号: 36919647001024670</p> <p>供应商服务: 非常满意 (5 stars) 按时发货: 非常满意 (5 stars)</p> <p>AML-S802 Quad-core Android embedded boar... ★★★★★ Good products</p> <p>Fast delivery low cost pcb fabrication O-leadin... ★★★★★ Good supplier</p>
<p>hot sale rigid-flexible PCB with 0.2mm BGA an... ★★★★★ very professional supplier</p> <p>High Quality custom FPCB/Flex PCB/FPC/Flexi... ★★★★★ Good product</p> <p>OEM ODM PCBA Bluetooth Wireless Marking G... ★★★★★ high soldering quality</p> <p>Electronic parts haptic pcba Circuit Board asse... ★★★★★ Very Good product</p>	<p>Lidar IR Sensor board pcba(H08R6x) ★★★★★ perfect product</p> <p>Customized PCBA design PCB design ★★★★★ perfect</p> <p>Audio Speaker and Headphone Jack (H07R3x) ★★★★★ High quality, good</p>
<p>订单编号: 37378603001024670</p> <p>供应商服务: 非常满意 (5 stars) 按时发货: 非常满意 (5 stars)</p> <p>Raspberry pi 0 Zero Raspberry Pi Zero PI W ver... ★★★★★ Fantastic products!!!</p> <p>double layer pcb with red S/M and LF-HASL su... ★★★★★ Good!</p>	<p>half hole pcb, half hole pcb module, half hole m... ★★★★★ Top half hole pcb supplier, very perfect goods</p> <p>High Quality custom FPCB/Flex PCB/FPC/Flexi... ★★★★★ this rigid-flexible pcb quality is perfect!</p> <p>Electronic parts haptic pcba Circuit Board asse... ★★★★★ Very satisfied with O-leading products and quality, especially their on-time delivery, fantastic!</p>

Be kind to your client, because he has many choices, but he chooses you instead.

Certifications

O-LEADING *TRAINING*



Keep *LEARNING*

There's a phrase in Buddhism, 'Beginner's mind.'

It's wonderful to have a beginner's mind

WE HAVE A *DREAM*

Keep *RUNNING*

I would like to live to study, and not study to live.

----Bacon

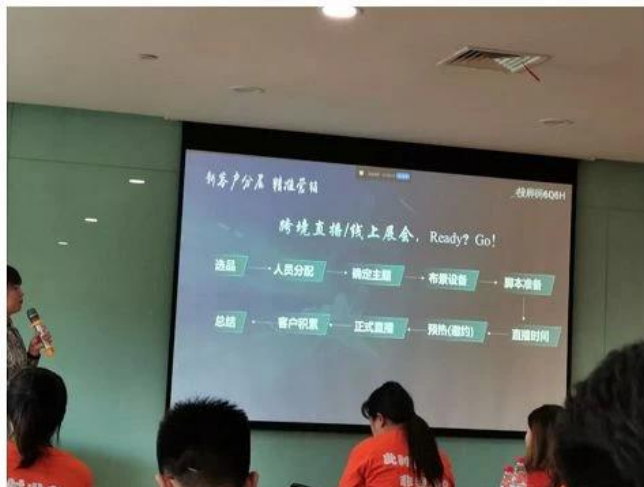



Test Report No. SZXEC1900530401 Date: 30 Mar 2019 Page 1 of 6

O-LEADING SUPPLY CHAIN (HK) CO., LIMITED
1313.FLOOR 13, FORTUNE BUILDING, DANSHUI TOWN, HUIYANG DISTRICT, HUIZHOU, GUANGDONG, CHINA

The following sample(s) was/were submitted and identified on behalf of the clients as : OSP

SGS Job No. : RP19-005089 - SZ
Date of Sample Received : 22 Mar 2019
Testing Period : 22 Mar 2019 - 30 Mar 2019
Test Requested : Selected tests(s) as requested by client.
Test Method : Please refer to next page(s).
Test Results : Please refer to next page(s).

Conclusion : Based on the performed tests on submitted sample(s), the results of Lead, Mercury, Cadmium, Hexavalent chromium, Polybrominated biphenyls (PBBs), Polybrominated diphenyl ethers (PBDEs) and Phthalates such as Bis(2-ethylhexyl) phthalate (DEHP), Butyl benzyl phthalate (BBP), Dibutyl phthalate (DBP), and Diisobutyl phthalate (DIBP) comply with the limits as set by RoHS Directive (EU) 2015/863 amending Annex II to Directive 2011/65/EU.

Signed for and on behalf of
SGS-CSTC Standards Technical Services Co., Ltd. Shenzhen Branch

Tina
Tina Fan
Approved Signatory



Unless otherwise agreed in writing, this document is issued by the Company subject to its General Conditions of Service printed on the reverse side of this document or available at www.sgs.com. The Client's attention is drawn to the limitation of liability, indemnification and jurisdiction clauses defined therein. Any holder of this document is advised that information contained herein reflects the Company's findings at the time of its intervention only and within the limits of the Client's instructions. In any event, the Company's sole responsibility is to its Client and the document does not exonerate parties to a transaction from respecting all their rights and obligations under the transaction documents. This document cannot be reproduced or used in any manner whatsoever without the prior written approval of the Company. Any unauthorized alteration, forgery or falsification of the content or appearance of this document is unlawful and offenders may be prosecuted to the fullest extent of the law. Unless otherwise stated the liability shown in this report refers only to the specific tested item.

Attention: To check the authenticity of testing SGS-CSTC Report & certificate, please contact us at telephone: (86-755) 8307 1443 or website: CN.sgs.com/verify

SGS 标准技术服务有限公司 深圳分公司 地址: 中国广东省深圳市宝安区西乡街道流塘社区 邮编: 518129 电话: (86-755) 25328888 / (86-755) 8307 1443
SGS 标准技术服务有限公司 深圳分公司 地址: 中国广东省深圳市宝安区西乡街道流塘社区 邮编: 518129 电话: (86-755) 25328888 / (86-755) 8307 1443

Member of the SGS Group (SGS SA)



Test Report No. SZXEC1900530401 Date: 30 Mar 2019 Page 2 of 6

Test Results :

Test Part Description :

Specimen No.	SGS Sample ID	Description
SN1	SZX19-005304.001	Green"PCB"

Remarks :

- (1) 1 mg/kg = 1 ppm = 0.0001%
- (2) MDL = Method Detection Limit
- (3) ND = Not Detected (< MDL)
- (4) "-" = Not Regulated

RoHS Directive (EU) 2015/863 amending Annex II to Directive 2011/65/EU

Test Method : With reference to IEC 62321-4:2013+A1:2017, IEC62321-5:2013, IEC62321-7-2:2017, IEC 62321-6:2015 and IEC62321-8:2017, analyzed by ICP-OES, UV-Vis and GC-MS.

Test Item(s)	Limit	Unit	MDL	0/1
Cadmium (Cd)	100	mg/kg	2	ND
Lead (Pb)	1,000	mg/kg	2	8
Mercury (Hg)	1,000	mg/kg	2	ND
Hexavalent Chromium (Cr(VI))	1,000	mg/kg	8	ND
Sum of PBBs	1,000	mg/kg	-	ND
Monobromobiphenyl	-	mg/kg	5	ND
Dibromobiphenyl	-	mg/kg	5	ND
Tribromobiphenyl	-	mg/kg	5	ND
Tetrabromobiphenyl	-	mg/kg	5	ND
Pentabromobiphenyl	-	mg/kg	5	ND
Hexabromobiphenyl	-	mg/kg	5	ND
Heptabromobiphenyl	-	mg/kg	5	ND
Octabromobiphenyl	-	mg/kg	5	ND
Nonabromobiphenyl	-	mg/kg	5	ND
Decabromobiphenyl	-	mg/kg	5	ND
Sum of PBDEs	1,000	mg/kg	-	ND
Monobromodiphenyl ether	-	mg/kg	5	ND
Dibromodiphenyl ether	-	mg/kg	5	ND
Tribromodiphenyl ether	-	mg/kg	5	ND
Tetrabromodiphenyl ether	-	mg/kg	5	ND
Pentabromodiphenyl ether	-	mg/kg	5	ND



Unless otherwise agreed in writing, this document is issued by the Company subject to its General Conditions of Service printed on the reverse side of this document or available at www.sgs.com. The Client's attention is drawn to the limitation of liability, indemnification and jurisdiction clauses defined therein. Any holder of this document is advised that information contained herein reflects the Company's findings at the time of its intervention only and within the limits of the Client's instructions. In any event, the Company's sole responsibility is to its Client and this document does not exonerate parties to a transaction from respecting all their rights and obligations under the transaction documents. This document cannot be reproduced or used in any manner whatsoever without the prior written approval of the Company. Any unauthorized alteration, forgery or falsification of the content or appearance of this document is unlawful and offenders may be prosecuted to the fullest extent of the law. Unless otherwise stated the liability shown in this report refers only to the specific tested item.

Attention: To check the authenticity of testing SGS-CSTC Report & certificate, please contact us at telephone: (86-755) 8307 1443 or website: CN.sgs.com/verify

SGS 标准技术服务有限公司 深圳分公司 地址: 中国广东省深圳市宝安区西乡街道流塘社区 邮编: 518129 电话: (86-755) 25328888 / (86-755) 8307 1443
SGS 标准技术服务有限公司 深圳分公司 地址: 中国广东省深圳市宝安区西乡街道流塘社区 邮编: 518129 电话: (86-755) 25328888 / (86-755) 8307 1443

Member of the SGS Group (SGS SA)



ZPMV2.E490354 - WIRING, PRINTED - COMPONENT

Wiring, Printed - Component

See General Information for Wiring, Printed - Component

O-LEADING SUPPLY CHAIN (HK) CO LTD
 ROOM 1205, 12/F
 TAI SANG BANK BLDG
 130-132 DES VOEUS ROAD
 CENTRAL, HONG KONG

E490354

Type	Cond Width		Cond Thk	SS/ DS/ DSO	Max	Max		Meets	C		
	Min	Edge			Area	Solder	Oper			Flame	
	mm(in)	mm(in)	mic(mil)		Diam	Limits	Temp	Class	UL796	T	
Multilayer (mass laminate) printed wiring boards.											
O-LEADING-401	0.1 (0.004)	0.3 (0.012)	34 (1.34)	DS	12.7 (0.5)	260	10	130	V-0	-	
O-LEADING-407	0.08 (0.003)	0.2 (0.008)	17 (0.67)	DS	9.7 (0.4)	260	10	130	V-0	All	
Multilayer printed wiring boards.											
O-LEADING-408	0.125 (0.005)	0.125 (0.005)	12 (0.47) Int:136	DS	50.8 (2.0)	280	20	130	V-0	All	*
Single layer printed wiring boards.											
O-LEADING-002	0.38 (0.015)	1.14 (0.045)	34 (1.34)	SS	19.1 (0.8)	260	10	105	V-0	All	-
O-LEADING-003	0.38 (0.015)	1.14 (0.045)	34 (1.34)	SS	19.1 (0.8)	260	10	130	V-0	▲	-
O-LEADING-033	0.15 (0.006)	0.3 (0.012)	34 (1.34)	SS	25.4 (1.0)	260	10	120	V-0	All	-
O-LEADING-205	0.1 (0.004)	0.3 (0.012)	34 (1.34)	DS	69.6 (2.7)	260	10	130	V-0	All	-
O-LEADING-206	0.15 (0.006)	0.33 (0.013)	17 (0.67)	DS	69.6 (2.7)	260	10	130	V-0	All	-
O-LEADING-D01	0.14 (0.006)	0.15 (0.006)	33 (1.30)	DS	25.4 (1.0)	260	10	130	V-0	All	*
O-LEADING-S01	0.25 (0.010)	0.25 (0.010)	17 (0.67)	SS	25.4 (1.0)	260	4	130	V-0	All	*

WIRING, PRINTED - COMPONENT | UL Product iQ

O-LEADING-S02	0.2 (0.008)	0.2 (0.008)	17 (0.67)	SS	25.4 (1.0)	260	4	130	HB	▲	*
O-LEADING-S03	0.25 (0.010)	0.25 (0.010)	34 (1.34)	SS	25.4 (1.0)	260	4	130	V-0	All	*

* - CTI marking is optional and may be marked on the printed wiring board.

Marking: Company name or file number and type designation. May be followed by a suffix to denote factory identification or burning test classification.

并不是所有出现在本数据库中的公司名称和产品都满足了UL跟踪检验服务的要求。只有带有UL标志的产品，才应该被视为经过UL认证，并满足UL跟踪检验服务的要求。注意查看产品上的标志。

UL 允许在线认证目录中所含材料的复制遵循以下条件：1.指南信息、装配、构造、设计、系统和/或认证（文件）必须在不篡改任何数据（或图纸）的情况下完整且无误导性地呈现。2.经 UL 允许从在线认证目录转载“声明必须出现在所提取材料的邻近位置。此外，转载材料必须包含以下格式的版权声明：“© 2019 UL LLC”

Capacité du processus

Capacités de production de PCB

Nombre de couches	1 couche-32 couche
Épaisseur de cuivre finie	1/3 oz-12 oz
Min Largeur de ligne / espacement interne	3,0 mil / 3,0 mil
Min Largeur de ligne / espacement externe	4,0 mil / 4,0 mil
Rapport hauteur / largeur maximum	10: 1
Épaisseur du panneau	0,2 mm à 5,0 mm
Taille maximale du panneau (pouces)	635 * 1500 mm
Taille minimale du trou percé	4 mil
Tolérance de trou Plated	+/- 3 mil
Blind / Buried Vias (types All)	OUI
Par remplissage (conducteur, non conducteur)	OUI
Matériel de base	FR-4, FR-4high Tg.Matériau sans halogène, Rogers, base en aluminium,Polyimide, cuivre lourd
Finitions de surface	HASL, OSP, ENIG, HAL-LF, Immersion argent,Immersion étain, doigts d'or, encre de carbone

Capacités de production SMT

Matériel PCB	FR-4, CEM-1, CEM-3, panneau à base d'aluminium, FPC
Taille maximale du PCB	510 x 1 500 mm
Taille minimale du PCB	50 x 50 mm
Épaisseur de PCB	0,5 mm à 4,5 mm
Épaisseur du panneau	0,5 à 4 mm
Taille minimale des composants	0201
Composant de taille de puce standard	0603 et plus
Hauteur max du composant	15 mm
Pas de plomb minimum	0,3 mm
Pas de balle min BGA	0,4 mm
Précision de placement	+/- 0,03 mm

Emballage et livraison

Shipping service



Quick Turn Lead Time		
Layer Count:	Lead Tim	Special Requirement
1L/2L	2-3days	24 Hours,48 Hours
4L	3-4days	48 Hours
6L	4-5days	72 Hours
8L	5-6days	NA
10L	6-7days	NA
12L	7-8days	NA
14L	8-9days	NA

Standard Lead Time		
Layer Count:	Sample Lead Time	Volume order lead time
2L	4 days	10 days
4L	5 days	11 days
6L	6 days	12 days
8L	8 days	14 days
10L	10 days	16 days
12L	12 days	18 days
14L	14 days	20 days
16-32L	18 days	24 days

FAQ

1. Comment O-Leading assure-t-il la qualité?

Notre standard de qualité élevé est atteint avec ce qui suit.

1.1 Le processus est strictement contrôlé selon les normes ISO 9001: 2008.

1.2 Utilisation étendue de logiciels dans la gestion du processus de production

1.3 Équipements et outils de test de pointe. Par exemple. Sonde volante, inspection aux rayons X, AOI (Automated Optical Inspector) et ICT (test in-circuit).

1.4 Équipe d'assurance qualité dédiée avec processus d'analyse des cas de défaillance

1.5 Formation et éducation continue du personnel

2. Comment O-Leading maintient-il votre prix compétitif?

Au cours de la dernière décennie, les prix de nombreuses matières premières (par exemple le cuivre, les produits chimiques) ont doublé, triplé ou quadruplé; La devise chinoise, le RMB, s'était apprécié de 31% par rapport au dollar américain; Et nos coûts de main-d'œuvre ont également augmenté de manière significative.

Cependant, O-Leading a maintenu nos prix stables. Cela dépend entièrement de nos innovations en matière de réduction des coûts, d'évitement des déchets et d'amélioration de l'efficacité. Nos prix sont très compétitifs dans l'industrie au même niveau de qualité.

Nous croyons en un partenariat gagnant-gagnant avec nos clients. Notre partenariat sera mutuellement

avantageux si nous pouvons vous fournir un coût et une qualité exceptionnels.

3. Quels types de cartes O-Leading peut-elle traiter?

Cartes courantes FR4, à haute TG et sans halogène, Rogers, Arlon, Telfon, cartes à base d'aluminium / cuivre, PI, etc.

4. Quelles données sont nécessaires pour la production de PCB et PCBA?

4.1 Nomenclature (Nomenclature) avec désignations de référence: description des composants, nom du fabricant et numéro de pièce.

4.2 Fichiers Gerber PCB.

4.3 Dessin de fabrication de PCB et dessin d'assemblage de PCBA.

4.4 Procédures d'essai.

4.5 Toutes restrictions mécaniques telles que les exigences de hauteur d'assemblage.

5. Quel est le flux de processus typique pour les PCB multicouches?

Découpe du matériau → Film sec interne → gravure interne → AOI interne → Multi-bond → Empilement de couches Pressage → Perçage → PTH → Placage de panneau → Film sec externe → Placage de motif → Gravure externe → AOI externe → Masque de soudure → Marque de composant → Finition de surface → Acheminement → E / T → Contrôle visuel.

6. Quels sont les équipements clés pour la fabrication HDI?

La liste des équipements clés est la suivante: perceuse laser, presse à presser, ligne VCP, machine d'exposition automatique, LDI, etc.

Les équipements dont nous disposons sont les meilleurs de l'industrie, les perceuses laser sont de Mitsubishi et Hitachi, les machines LDI de Screen (Japon), les machines d'exposition automatique sont également de Hitachi, elles nous permettent de répondre aux exigences techniques du client.

7. Combien de types de finition de surface O-plomb peuvent faire?

O-the leader a la série complète de finitions de surface, telles que: ENIG, OSP, LF-HASL, placage d'or (doux / dur), argent d'immersion, étain, placage d'argent, placage d'étain par immersion, encre de carbone et etc. ... OSP, ENIG, OSP + ENIG couramment utilisés sur le HDI, nous vous recommandons généralement d'utiliser un client ou OSP OSP + ENIG si la taille du BGA PAD est inférieure à 0,3 mm.

8. Quelle est votre capacité pour FPC? O-Leading peut-il également fournir un service SMT?

O-Leading peut fabriquer du FPC d'une seule couche à 8 couches, la taille du panneau de travail peut être aussi grande que 2000 mm * 240 mm, veuillez trouver les détails dans la page «Flex Capability» Nous fournissons également un service SMT à guichet unique au client.

9. Quels sont les principaux facteurs qui affecteront le prix des PCB?

Matériel;

Finition de surface;

Difficulté technologique;

Différents critères de qualité;

Les caractéristiques des PCB;

Modalités de paiement;

Différents pays de fabrication.

10. Quelle est la définition des PCB, PWB et FPC et quelle est la différence?

PCB est l'abréviation de Circuit imprimé;

PWB est l'abréviation de Printed Wire Board, au même sens que Printed Circuit Board;

FPC est l'abréviation de Flexible Printed Board.

11. Quels facteurs faut-il prendre en compte lors du choix du matériau pour une carte PCB?

Les facteurs ci-dessous doivent être pris en compte lorsque nous choisissons le matériau pour PCB:

La valeur Tg du matériau doit être supérieure à la température de fonctionnement;

Le matériau à faible CTE a de bonnes performances de stabilité thermique;

Bonnes performances de résistance thermique: Normalement, les circuits imprimés doivent résister à 250 °C pendant au moins 50 s.

Bonne planéité; Compte tenu des propriétés électriques, un matériau à faible perte / haute permittivité est utilisé sur les circuits imprimés haute fréquence; Substrat en fibre de verre polyimide utilisé pour les circuits imprimés flexibles; Le noyau métallique est utilisé lorsque le produit a des exigences strictes en matière de dissipation thermique.

12. Quels sont les avantages du PCB rigide-flex d'O-Leading?

Le PCB rigide-flex de O-Leading a les caractères FPC et PCB, il peut donc être utilisé dans certains produits spéciaux. Une partie est flexible tandis que l'autre est rigide, elle peut aider à économiser l'espace intérieur du produit, à réduire le volume du produit et à améliorer les performances.

13. Comment faire le calcul de l'impédance?

Le système de contrôle d'impédance se fait à l'aide de quelques coupons de test, du logiciel SI6000 et de l'équipement CITS 500s de POLAR INSTRUMENTS.

L'équipement mesure l'impédance sur un coupon de configuration de piste représentatif dont le client nous a donné une valeur et une tolérance déterminées.