

Tervetuloa O-Leadingiin

O-Leading pyrkii olemaan yhden luokun kumppanisi EMS-toimitusketjussa, mukaan lukien piirilevyjen suunnittelu, piirilevyjen valmistus ja piirilevyjen kokoonpano. Tarjoamme joitain edistyneimpiä piirilevyteknikoita, mukaan lukien HDI-piirilevyt, monikerroksiset piirilevyt, jäykät ja joustavat piirilevyt. tuki prototyypin nopeasta kääntämisestä keski- ja massatuotantoon.

Yleisesti ottaen globaalit asiakkaamme ovat erittäin vaikuttuneita palveluistamme: nopea reagointi, kilpailukykyinen hinta ja sitoutuminen laatuun. Arvokkaamman teknisen palvelun ja kokonaisratkaisun tarjoaminen on tapa johtaa O: ta eteenpäin.

Tulevaisuuden näkökulmasta O-Leading keskittyy elektroniikan valmistusteknologian innovaatioihin ja kehitykseen kuten aina, ja pyrkii jatkuvasti jatkamaan piirilevyjen ja PCBA: n yhden luokun palvelua tarjoamaan ensiluokkaisia palveluja ja luomaan enemmän arvoa asiakkaillemme.

LISÄÄ TIETOJA KLIKKAAMALLA NÄITÄ [Piirilevyn elektroninen piirilevykokoonpanotehdas](#)

O-LEADING
To Be **Reliable**, To Be **Valuable**

WE ALWAYS PROVIDE YOU

BEST HIGH DENSITY INTERCONNECT PCB

WE ALWAYS PROVIDE YOU

BEST RIGID-FLEXIBLE CIRCUIT

Tuotteen Kuvaus

Raspberry Pi 3 -malli A +, eniten parannuksia kuin Raspberry Pi 3B +, pienemmässä muodossa ja halvempi ([Raspberry Pi: n ammattimainen jäykkä joustava piirilevytoimittaja](#))

Yleiskatsaus

Puolittamalla RAM-muistin 512 Mt: iin ja irrottamalla USB-keskittimen ja Ethernet-ohjaimen, Raspberry Pi 3 Model A + pystyy pienentymään kooltaan ja osui alempaan hintapisteeseen.

Raspberry Pi 3 -malli A + sisältää suurimman osan siististä parannuksista isoveljensä Raspberry Pi 3B + -ominaisuutena ja sisältää:

- * 1,4 GHz: n 64-bittinen neliytiminen ARM Cortex-A53 -prosessori
- * 512 Mt LPDDR2 SDRAM -muisti
- * Kaksikaistainen 802.11ac-langaton lähiverkko ja Bluetooth 4.2 / BLE
- * Parannettu USB-massamuistikäynnistys
- * Parempi lämmönhallinta

Isoveljensä tavoin koko levy on sertifioitu radiomoduuliksi FCC: n sääntöjen mukaisesti, mikä puolestaan vähentää merkittävästi Raspberry Pi -pohjaisten tuotteiden vaatimustenmukaisuuden testaamisen kustannuksia.

TOP QUALITY PCBA

O-LEADING

To Be Reliable, To Be Valuable



MAKE YOUR IDEA COME TRUE

Tekniset tiedot

- * Broadcom BCM2837B0, Cortex-A53 (ARMv8) 64-bittinen SoC @ 1,4 GHz
- * 512 Mt LPDDR2 SDRAM -muisti
- * 2,4 GHz ja 5 GHz IEEE 802.11. B / g / n / ac langaton lähiverkko, Bluetooth 4.2 / BLE
- * Ei Ethernet-porttia
- * Laajennettu 40-nastainen GPIO-otsikko
- * Täysikokoinen HDMI
- * Yksi USB 2.0 -portti
- * CSI-kameraportti Raspberry Pi -kameramoduulin liittämistä varten
- * DSI-näyttöportti Raspberry Pi -kosketusnäytön liittämistä varten
- * 4-napainen stereolähtö ja komposiittivideoportti
- * Micro SD -portti käyttöjärjestelmän lataamiseen ja tietojen tallentamiseen
- * 5 V / 2,5 A tasavirta

TOP QUALITY PCBA

O-LEADING
To Be **Reliable**, To Be **Valuable**



MAKE YOUR IDEA COME **TRUE**

TOP QUALITY PCBA

O-LEADING
To Be **Reliable**, To Be **Valuable**



MAKE YOUR IDEA COME **TRUE**

TOP QUALITY PCBA

O-LEADING
To Be **Reliable**, To Be **Valuable**

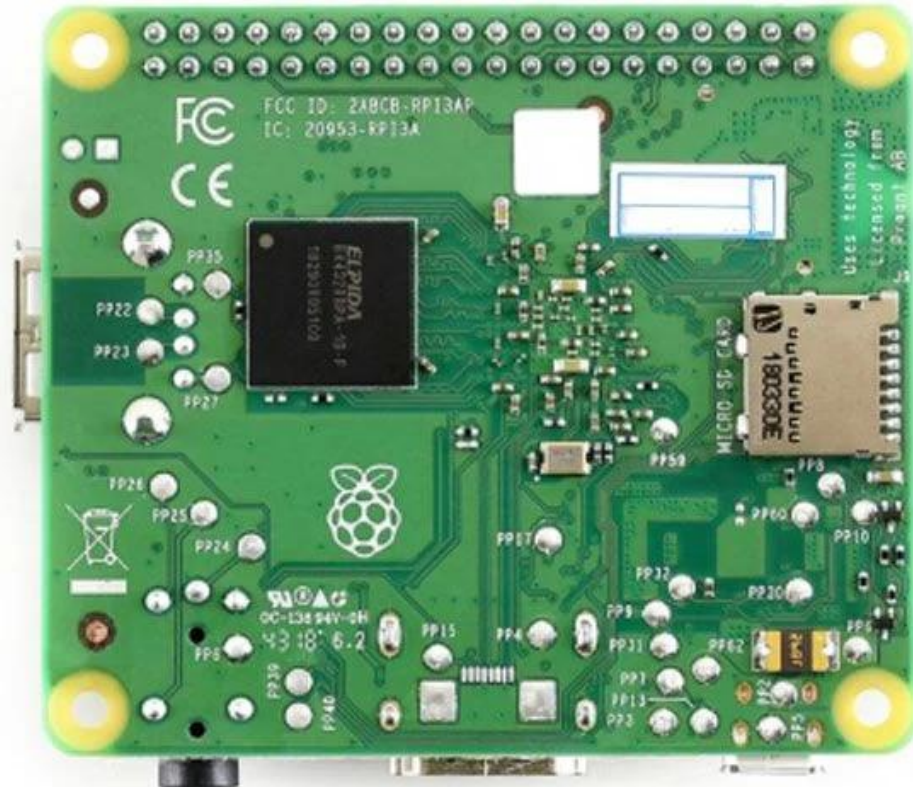

MAKE YOUR IDEA COME **TRUE**

TOP QUALITY PCBA

O-LEADING
To Be Reliable, To Be Valuable



MAKE YOUR IDEA COME **TRUE**

Tiimimme

O-LEADING CUSTOMER

To be **RELIABLE**

- Q**uality first ,
- C**ustomer supreme ,
- S**cientifically management ,
- S**triving for famous brand



THE CUSTOMER IS KING



To be **VALUABLE**

- S**cience and technology keeps head ,
- P**ut people first ,
- B**e precise and practical ,
- C**ontribute sincerely

Factory PCB



Automatic vacuum press machine



Drilling Machine



Pattern Plating Machine



Scrubbing Machine



Developing Machine



Routing Machine



High-speed flying probe machine



E-test Machine

Factory SMT



HOW O-LEADING MAKE A PROJECT FOR YOU

Hardware Dispenser Application Not

Automatic Dispenser Application Not

Voltage Table

Volt Pin Number	Description
VDD	Battery voltage
+3V3	+3.3V
+5V	+5V
USB +5V	USB 5V input
+5V/2	Isolated +5V
+12V	12V DC Drive

STM32F072 PINOUT table

Wire Name	Description	DIO	Mode	Note
SMTN_TOF	Shutdown Time of flight sensor		Output	Logic '0' to shutdown
I2C_SCL_TOF	I2C communication with time of flight sensor		I2C1 SCL	
I2C_SDA_TOF	I2C communication with thermopile sensor		I2C1 SDA	
I2C_SCL_IR	I2C communication with thermopile sensor		I2C2 SCL	
I2C_SDA_IR	I2C communication with thermopile sensor		I2C2 SDA	
RATE_LC	Load cell control pins		Output	
DOUT_LC	Load cell control pins		Output	

O-LEADING
TO BE RELIABLE, TO BE AVAILABLE

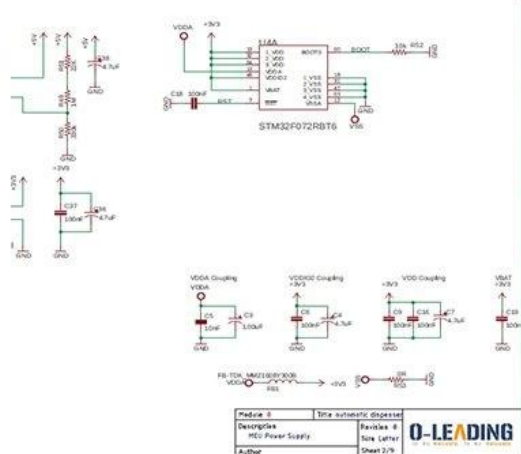

HARDWARE schematics

PCB PRODUCTION COMPONENTS SOURCING

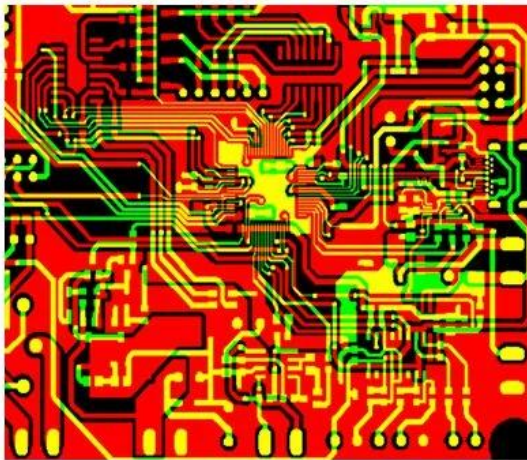

Qty	Value	Device	Parts	Description
4	AK500/2	AK500/2	X1, X2	CONNECTOR
1	AK500/3	AK500/3	X7	CONNECTOR
1	1241148	MA04-2	SV2	
1	PPPC04	MA04-2	SV1	8 POS, 4*2 FEMALE PIN HEAD
1	ML10	ML10	SV4	HARTING
1	8MHZ	XTALL_CSTCE8M	X5	STCE8M00G52-R0 RESONATOR
1	0R	R-0603	R53	Thick Film Resistors - SMD 0603
2	10R	R-0603	R12, R5	Thick Film Resistors - SMD 0603
8	100R	R-0603	R1, R2	Thick Film Resistors - SMD 0603
1	270R	R-0805	R15	Thick Film Resistors - SMD 0605
1	330R	R-0603	R11	Thick Film Resistors - SMD 0603
9	680R	R-0603	R20, R3	Thick Film Resistors - SMD 0603
17	1k	R-0603	R9, R10	Thick Film Resistors - SMD 0603
2	4.7k	R-0603	R17, R6	Thick Film Resistors - SMD 0603
2	5.1k	R-0603	R18, R1	Thick Film Resistors - SMD 0603
9	10k	R-0603	R16, R3	Thick Film Resistors - SMD 0603
9	10k	R-0603	R20, R1	Thick Film Resistors - SMD 0603

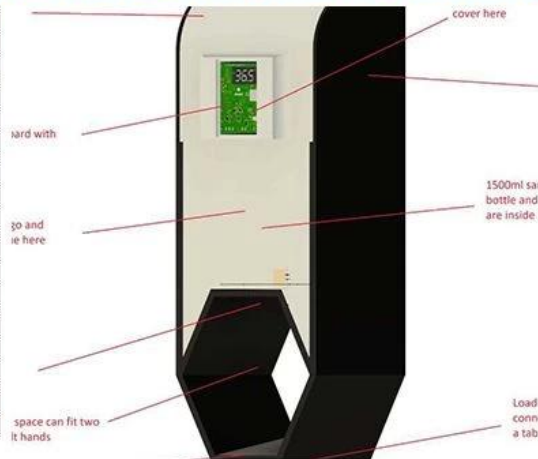

PCB Assembly MECHANICAL DESIGN

Skyworth 创维

HET 和而泰
HET INTELLIGENT CONTROL

dongweikeji
东威科技

美的 Midea

STAR-NET
星网锐捷

FORYOU
ADAYO 华阳集团

EDIFIER[®]

Cultraview 金锐显

3nod 三诺

T&W

TCL

AcBel 康舒科技
ACBEL POLYTECH INC.

Honeywell

Schneider
Electric

ZTE 中兴

EMERSON

BYD

PHILIPS

TE
connectivity

VIDEOTON

CUSTOMER VOICE IS **EXTREMELY IMPORTANT** TO US

订单编号: 49335463501024670

供应商服务: 非常满意 (5 stars) 按时发货: 非常满意 (5 stars)



High quality usb power pcb , pcba manufacturer

★★★★★

Fancy has done an excellent job, whenever we write, she answered us within 1 second, O-leading is very perfect with fast delivery, fast logistics, the most important thing is good quality, good packaging, thank you!

[回复该评论](#)



oem customized rohs pcb drawing schematic s...

★★★★★

We received the boards, the quality is very good, the price is very reasonable, Fancy is very nice & smart & experienced, the logistics is super fast, I will come to see more in the future.

[回复该评论](#)

订单编号: 490224962001024670

United States

供应商服务: 非常满意 (5 stars) 按时发货: 非常满意 (5 stars)



High TG180 FR-4 Circuit HDI PCB 94V0 Board...

★★★★★

This is a very difficult PCB design, but we are lucky to find O-leading to support the PCB for us very good to a PCB supplier.



universal FR4 Multilayer PCB washing machine...

★★★★★

Fancy gives us very excellent service, very professional and experienced, O-leading is the best one of our suppliers, very happy to work with them.

订单编号: 49298271001024670

供应商服务: 非常满意 (5 stars) 按时发货: 非常满意 (5 stars)



High TG180 FR-4 Circuit HDI PCB 94V0 Board ...

★★★★★

perfect product, perfect PCB supplier!

[回复该评论](#)



oem customized rohs pcb drawing schematic s...

★★★★★

Very good and professional PCB product as usual!

[回复该评论](#)



Strip LED Aluminum FR-4 lighting PCB board 9...

★★★★★

High quality, fast delivery, good service, competitive price, lucky and happy to purchase from O-leading!

[回复该评论](#)

订单编号: 4939862201024670

供应商服务: 非常满意 (5 stars) 按时发货: 非常满意 (5 stars)



High quality Keyboard pcb & pcba Factory SMT...

★★★★★

Top quality, it's the right choice to choose O-leading to make the PCB & PCBA

[回复该评论](#)



Professional Printed Circuit Board Manufactur...

★★★★★

Very high quality PCB products, O-leading is the best PCB supplier that we have ever worked with.

订单编号: 44068794501034670

供应商服务: 非常满意 (5 stars) 按时发货: 非常满意 (5 stars)



High TG180 FR-4 Circuit HDI PCB 94V0 Board ...

★★★★★

We bought two batches, one by DHL, the other one by air, good quality and fast delivery!

LISTEN TO **CUSTOMER VOICE**

订单编号: 40903347501024670

供应商服务: 非常满意 (5 stars) 按时发货: 非常满意 (5 stars)



Strip LED Aluminum FR-4 lighting PCB board 9...

★★★★★

Very fast delivery! Fantastic, good job!!



Professional Printed Circuit Board Manufactur...

★★★★★

Very happy to great support from O-leading, they are not only professional on the PCB, but also provide good PCB products, very good supplier!

订单编号: 36919647001024670

供应商服务: 非常满意 (5 stars) 按时发货: 非常满意 (5 stars)



AML-S802 Quad-core Android embedded boar...

★★★★★

Good products



Fast delivery low cost pcb fabrication O-leadin...

★★★★★

Good supplier

订单编号: 37378603001024670

供应商服务: 非常满意 (5 stars) 按时发货: 非常满意 (5 stars)



hot sale rigid-flexible PCB with 0.2mm BGA an...

★★★★★

very professional supplier



High Quality custom FPCB/Flex PCB/FPC/Flexi...

★★★★★

Good product



OEM ODM PCBA Bluetooth Wireless Marking G...

★★★★★

high soldering quality



Electronic parts haptic pcba Circuit Board asse...

★★★★★

Very Good product

订单编号: 36919647001024670

供应商服务: 非常满意 (5 stars) 按时发货: 非常满意 (5 stars)



Lidar IR Sensor board pcba(H08R6x)

★★★★★

perfect product



Customized PCBA design PCB design

★★★★★

perfect



Audio Speaker and Headphone Jack (H07R3x)

★★★★★

High quality, good

订单编号: 37378603001024670

供应商服务: 非常满意 (5 stars) 按时发货: 非常满意 (5 stars)



Raspberry pi 0 Zero Raspberry Pi Zero PI W ver...

★★★★★

Fantastic products!!



double layer pcb with red S/M and LF-HASL su...

★★★★★

Good!

订单编号: 36919647001024670

供应商服务: 非常满意 (5 stars) 按时发货: 非常满意 (5 stars)



half hole pcb, half hole pcb module, half hole m...

★★★★★

Top half hole pcb supplier, very perfect goods



High Quality custom FPCB/Flex PCB/FPC/Flexi...

★★★★★

this rigid-flexible pcb quality is perfect!



Electronic parts haptic pcba Circuit Board asse...

★★★★★

Very satisfied with O-leading products and quality, especially their on-time delivery, fantastic!

Be **kind** to your client, because he has many choices, but he chooses you instead.

Sertifikaatit

O-LEADING *TRAINING*



Keep *LEARNING*

There's a phrase in Buddhism, 'Beginner's mind.'

It's wonderful to have a beginner's mind

WE HAVE A *DREAM*

Keep *RUNNING*

I would like to live to study, and not study to live.

----Bacon

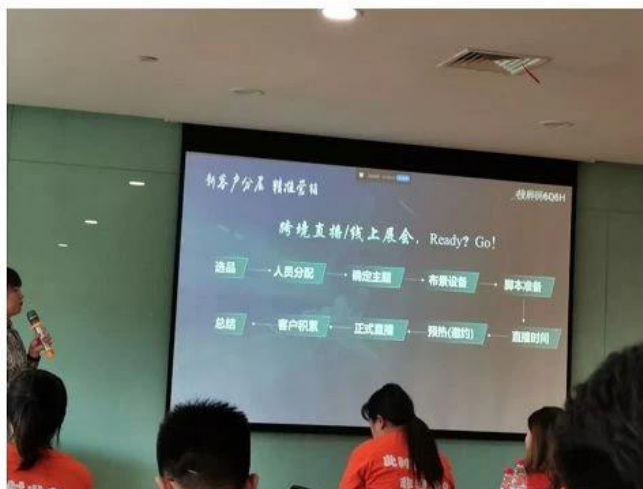



Test Report No. SZXEC1900530401 Date: 30 Mar 2019 Page 1 of 6

O-LEADING SUPPLY CHAIN (HK) CO., LIMITED
1313.FLOOR 13, FORTUNE BUILDING, DANSHUI TOWN, HUIYANG DISTRICT, HUIZHOU, GUANGDONG, CHINA

The following sample(s) was/were submitted and identified on behalf of the clients as : OSP

SGS Job No. : RP19-005089 - SZ
Date of Sample Received : 22 Mar 2019
Testing Period : 22 Mar 2019 - 30 Mar 2019
Test Requested : Selected tests(s) as requested by client.
Test Method : Please refer to next page(s).
Test Results : Please refer to next page(s).

Conclusion : Based on the performed tests on submitted sample(s), the results of Lead, Mercury, Cadmium, Hexavalent chromium, Polybrominated biphenyls (PBBs), Polybrominated diphenyl ethers (PBDEs) and Phthalates such as Bis(2-ethylhexyl) phthalate (DEHP), Butyl benzyl phthalate (BBP), Dibutyl phthalate (DBP), and Diisobutyl phthalate (DIBP) comply with the limits as set by RoHS Directive (EU) 2015/863 amending Annex II to Directive 2011/65/EU.

Signed for and on behalf of
SGS-CSTC Standards Technical Services Co., Ltd. Shenzhen Branch

Tina
Tina Fan
Approved Signatory



Unless otherwise agreed in writing, this document is issued by the Company subject to its General Conditions of Service printed on the reverse side of this document or available at www.sgs.com. The Client's attention is drawn to the limitation of liability, indemnification and jurisdiction clauses defined therein. Any holder of this document is advised that information contained herein reflects the Company's findings at the time of its intervention only and within the limits of the Client's instructions. In any event, the Company's sole responsibility is to its Client and the document does not exonerate parties to a transaction from respecting all their rights and obligations under the transaction documents. This document cannot be reproduced or used in any manner whatsoever without the prior written approval of the Company. Any unauthorized alteration, forgery or falsification of the content or appearance of this document is unlawful and offenders may be prosecuted to the fullest extent of the law. Unless otherwise stated the liability shown in this report refers only to the specific tested item.

Attention: To check the authenticity of testing SGS/CSTC Report & certificate, please contact us at telephone: (86-755) 8307 1443 or website: CN.sgs.com

SGS 检测有限公司 深圳分公司 地址: 深圳市福田区福安路 518129 邮编: 518129 电话: (86-755) 25288888 / (86-755) 8307 1443
SGS 检测有限公司 深圳分公司 地址: 深圳市福田区福安路 518129 邮编: 518129 电话: (86-755) 25288888 / (86-755) 8307 1443

Member of the SGS Group (SGS SA)



Test Report No. SZXEC1900530401 Date: 30 Mar 2019 Page 2 of 6

Test Results :

Test Part Description :

Specimen No.	SGS Sample ID	Description
SN1	SZX19-005304.001	Green"PCB"

- Remarks :
- (1) 1 mg/kg = 1 ppm = 0.0001%
 - (2) MDL = Method Detection Limit
 - (3) ND = Not Detected (< MDL)
 - (4) "-" = Not Regulated

RoHS Directive (EU) 2015/863 amending Annex II to Directive 2011/65/EU

Test Method : With reference to IEC 62321-4:2013+A1:2017, IEC62321-5:2013, IEC62321-7-2:2017, IEC 62321-6:2015 and IEC62321-8:2017, analyzed by ICP-OES, UV-Vis and GC-MS.

Test Item(s)	Limit	Unit	MDL	0/1
Cadmium (Cd)	100	mg/kg	2	ND
Lead (Pb)	1,000	mg/kg	2	8
Mercury (Hg)	1,000	mg/kg	2	ND
Hexavalent Chromium (Cr(VI))	1,000	mg/kg	8	ND
Sum of PBBs	1,000	mg/kg	-	ND
Monobromobiphenyl	-	mg/kg	5	ND
Dibromobiphenyl	-	mg/kg	5	ND
Tribromobiphenyl	-	mg/kg	5	ND
Tetrabromobiphenyl	-	mg/kg	5	ND
Pentabromobiphenyl	-	mg/kg	5	ND
Hexabromobiphenyl	-	mg/kg	5	ND
Heptabromobiphenyl	-	mg/kg	5	ND
Octabromobiphenyl	-	mg/kg	5	ND
Nonabromobiphenyl	-	mg/kg	5	ND
Decabromobiphenyl	-	mg/kg	5	ND
Sum of PBDEs	1,000	mg/kg	-	ND
Monobromodiphenyl ether	-	mg/kg	5	ND
Dibromodiphenyl ether	-	mg/kg	5	ND
Tribromodiphenyl ether	-	mg/kg	5	ND
Tetrabromodiphenyl ether	-	mg/kg	5	ND
Pentabromodiphenyl ether	-	mg/kg	5	ND



Unless otherwise agreed in writing, this document is issued by the Company subject to its General Conditions of Service printed on the reverse side of this document or available at www.sgs.com. The Client's attention is drawn to the limitation of liability, indemnification and jurisdiction clauses defined therein. Any holder of this document is advised that information contained herein reflects the Company's findings at the time of its intervention only and within the limits of the Client's instructions. In any event, the Company's sole responsibility is to its Client and this document does not exonerate parties to a transaction from respecting all their rights and obligations under the transaction documents. This document cannot be reproduced or used in any manner whatsoever without the prior written approval of the Company. Any unauthorized alteration, forgery or falsification of the content or appearance of this document is unlawful and offenders may be prosecuted to the fullest extent of the law. Unless otherwise stated the liability shown in this report refers only to the specific tested item.

Attention: To check the authenticity of testing SGS/CSTC Report & certificate, please contact us at telephone: (86-755) 8307 1443 or website: CN.sgs.com

SGS 检测有限公司 深圳分公司 地址: 深圳市福田区福安路 518129 邮编: 518129 电话: (86-755) 25288888 / (86-755) 8307 1443
SGS 检测有限公司 深圳分公司 地址: 深圳市福田区福安路 518129 邮编: 518129 电话: (86-755) 25288888 / (86-755) 8307 1443

Member of the SGS Group (SGS SA)



ZPMV2.E490354 - WIRING, PRINTED - COMPONENT

Wiring, Printed - Component

See General Information for Wiring, Printed - Component

O-LEADING SUPPLY CHAIN (HK) CO LTD
 ROOM 1205, 12/F
 TAI SANG BANK BLDG
 130-132 DES VOEUS ROAD
 CENTRAL, HONG KONG

E490354

Type	Cond Width		Cond Thk mic(mil)	SS/ DS/ DSO	Max	Max		Meets	C		
	Min	Edge			Area	Solder	Oper			Flame	
	mm(in)	mm(in)			Diam mm(in)	Limits C	Temp sec	Class C	UL796 DSR	I	
Multilayer (mass laminate) printed wiring boards.											
O-LEADING-401	0.1 (0.004)	0.3 (0.012)	34 (1.34)	DS	12.7 (0.5)	260	10	130	V-0	-	-
O-LEADING-407	0.08 (0.003)	0.2 (0.008)	17 (0.67)	DS	9.7 (0.4)	260	10	130	V-0	All	-
Multilayer printed wiring boards.											
O-LEADING-408	0.125 (0.005)	0.125 (0.005)	12 (0.47) Int:136	DS	50.8 (2.0)	280	20	130	V-0	All	*
Single layer printed wiring boards.											
O-LEADING-002	0.38 (0.015)	1.14 (0.045)	34 (1.34)	SS	19.1 (0.8)	260	10	105	V-0	All	-
O-LEADING-003	0.38 (0.015)	1.14 (0.045)	34 (1.34)	SS	19.1 (0.8)	260	10	130	V-0	▲	-
O-LEADING-033	0.15 (0.006)	0.3 (0.012)	34 (1.34)	SS	25.4 (1.0)	260	10	120	V-0	All	-
O-LEADING-205	0.1 (0.004)	0.3 (0.012)	34 (1.34)	DS	69.6 (2.7)	260	10	130	V-0	All	-
O-LEADING-206	0.15 (0.006)	0.33 (0.013)	17 (0.67)	DS	69.6 (2.7)	260	10	130	V-0	All	-
O-LEADING-D01	0.14 (0.006)	0.15 (0.006)	33 (1.30)	DS	25.4 (1.0)	260	10	130	V-0	All	*
O-LEADING-S01	0.25 (0.010)	0.25 (0.010)	17 (0.67)	SS	25.4 (1.0)	260	4	130	V-0	All	*

WIRING, PRINTED - COMPONENT | UL Product iQ

O-LEADING-S02	0.2 (0.008)	0.2 (0.008)	17 (0.67)	SS	25.4 (1.0)	260	4	130	HB	▲	*
O-LEADING-S03	0.25 (0.010)	0.25 (0.010)	34 (1.34)	SS	25.4 (1.0)	260	4	130	V-0	All	*

* - CTI marking is optional and may be marked on the printed wiring board.

Marking: Company name or file number and type designation. May be followed by a suffix to denote factory identification or burning test classification.

并不是所有出现在本数据库中的公司名称和产品都满足了UL跟踪检验服务的要求。只有带有UL标志的产品，才应该被视为经过UL认证，并满足UL跟踪检验服务的要求。注意查看产品上的标志。

UL 允许在线认证目录中所含材料的复制遵循以下条件：1.指南信息、装配、构造、设计、系统和/或认证（文件）必须在不篡改任何数据（或图纸）的情况下完整且无误导性地呈现。2.经UL允许从在线认证目录转载“声明必须出现在所摘取材料的邻近位置。此外，转载材料必须包含以下格式的版权声明：“© 2019 UL LLC”

Prosessikapasiteetti

Piirilevyjen tuotantokapasiteetti

Kerroslaskenta	1 kerros-32 kerros
Valmiit kuparipaksuudet	1 / 3oz-12oz
Pienin viivan leveys / sisäinen etäisyys	3,0mil / 3,0mil
Pienin viivan leveys / väli ulkoinen	4,0mil / 4,0mil
Suurin kuvasuhde	10: 1
Levyn paksuus	0,2 - 5,0 mm
Paneelin enimmäiskoko (tuumaa)	635 * 1500mm
Porattu reikien vähimmäiskoko	4mil
Kiinnitetty reiän suvaitsevaisuus	+/- 3mil
Blind / Buried Vias (All-tyypit)	JOO
Täytön kautta (johtava, ei-johtava)	JOO
Pohjamateriaalia	FR-4, FR-4korkea Tg Halogeeniton materiaali, Rogers, Alumiinipohja, Polyimidi, raskas kupari
Pintakäsittely	HASL, OSP, ENIG, HAL-LF, Immersion hopea, Immersion Tin, kultaiset sormet, hiilimustetta

SMT-tuotantokapasiteetti

PCB-materiaali	FR-4, CEM-1, CEM-3, alumiinipohjainen levy, FPC
Max PCB-koko	510x1500mm
Pienin piirilevykoko	50x50mm
Piirilevyn paksuus	0,5 - 4,5 mm
Levyn paksuus	0,5-4 mm
Komponenttien vähimmäiskoko	0201
Normaali sirukokoinen komponentti	0603 tai suurempi
Komponentin enimmäiskorkeus	15mm
Pienin lyijyn nousu	0,3 mm
Pienin BGA-pallokenttä	0,4 mm
Sijoittamisen tarkkuus	+/- 0,03 mm

Pakkaus ja toimitus

Shipping service



Quick Turn Lead Time		
Layer Count:	Lead Tim	Special Requirement
1L/2L	2-3days	24 Hours,48 Hours
4L	3-4days	48 Hours
6L	4-5days	72 Hours
8L	5-6days	NA
10L	6-7days	NA
12L	7-8days	NA
14L	8-9days	NA

Standard Lead Time		
Layer Count:	Sample Lead Time	Volume order lead time
2L	4 days	10 days
4L	5 days	11 days
6L	6 days	12 days
8L	8 days	14 days
10L	10 days	16 days
12L	12 days	18 days
14L	14 days	20 days
16-32L	18 days	24 days

UKK

1. Kuinka O-Leading varmistaa laadun?

Korkea laatutaso saavutetaan seuraavilla tavoilla.

1.1 Prosessia valvotaan tiukasti ISO 9001: 2008 -standardien mukaisesti.

1.2 Ohjelmistojen laaja käyttö tuotantoprosessin hallinnassa

1.3 Huipputason testauslaitteet ja työkalut. Esimerkiksi. Flying Probe, röntgentarkastus, AOI (automatoitu optinen tarkastaja) ja ICT (piirin sisäinen testaus).

1.4 Erityinen laadunvarmistusryhmä vikatapausten analysointiprosessilla

1.5 Henkilöstön jatkuva koulutus

2. Kuinka O-Leading pitää hintasi kilpailukykyisenä?

Viime vuosikymmenen aikana monien raaka-aineiden (esim. Kupari, kemikaalit) hinnat ovat kaksinkertaistuneet, kolminkertaistuneet tai nelinkertaistuneet; Kiinan valuutan RMB oli noussut 31% Yhdysvaltain dollariin nähden; Ja myös työvoimakustannuksemme nousivat merkittävästi.

O-Leading on kuitenkin pitänyt hintamme vakaana. Tämä omistaa kokonaan innovaatiomme kustannusten vähentämisessä, jätteen välttämässä ja tehokkuuden parantamisessa. Hintamme ovat erittäin kilpailukykyisiä teollisuudessa samalla laatutasolla.

Uskomme win-win-kumppanuuteen asiakkaidemme kanssa. Kumppanuudestamme on molemminpuolista hyötyä, jos voimme tarjota sinulle edun kustannuksia ja laatua.

3. Millaisia levyjä O-johtava voi käsitellä?

Yleiset FR4-, korkea-TG- ja halogeenittomat levyt, Rogers, Arlon, Telfon, alumiini / kuparipohjaiset levyt, PI jne.

4. Mitä tietoja tarvitaan PCB- ja PCBA-tuotantoon?

4.1 BOM (Bill of Materials) viitetunnisteilla: osan kuvaus, valmistajan nimi ja osanumero.

4.2 Piirilevyn Gerber-tiedostot.

4.3 Piirilevyjen valmistuspiirustus ja PCBA-kokoonpanopiirustus.

4.4 Testimenettelyt.

4.5 Mahdolliset mekaaniset rajoitukset, kuten kokoonpanon korkeusvaatimukset.

5. Mikä on tyypillinen prosessivirta monikerroksiselle piirilevyille?

Materiaalin leikkaus → Sisempi kuiva kalvo → sisäinen syövytys → Sisempi AOI → Monisidos → Kerrospinoylös Puristaminen → Poraus → PTH → Paneelipinnoitus → Ulkokuiva kalvo → Kuvion pinnoitus → Ulkoinen syövytys → Ulkoinen AOI → Juotosmaski → Komponenttimerkki → Pintakäsittely → Reititys → E / T → Silmämääräinen tarkastus.

6. Mitkä ovat HDI-valmistuksen tärkeimmät laitteet?

Tärkeimpien laitteiden luettelo on seuraava: Laserporakone, puristuskone, VCP-linja, automaattinen valotuskone, LDI ja niin edelleen.

Laitteemme ovat alan parhaita, laserporakoneet ovat Mitsubishilta ja Hitachilta, LDI-koneet ovat Screeniltä (Japani), Automaattiset valotuslaitteet ovat myös Hitachilta, jotka kaikki tekevät meistä vastaamaan asiakkaan teknisiin vaatimuksiin.

7. Kuinka monen tyypistä pintakäsittelyä O-lyijy voi tehdä?

O-johtajalla on täysi sarja pintakäsittelyjä, kuten: ENIG, OSP, LF-HASL, kulloitus (pehmeä / kova), uppohopea, tina, hopeapinnoitus, upotettava tinan pinnoitus, hiilimuste ja niin edelleen. HDI: ssä yleisesti käytetty OSP, ENIG, OSP + ENIG, suosittelemme yleensä asiakkaan tai OSP OSP + ENIG: n käyttöä, jos BGA PAD -koko on alle 0,3 mm.

8. Mikä on kykyisi FPC: lle? Voiko O-Leading tarjota myös SMT-palvelua?

O-Leading voi valmistaa FPC: n yksikerroksisesta 8-kerrokseen, työpaneelin koko voi olla jopa 2000 mm * 240 mm, katso yksityiskohdat sivulta "Flex Capability"

Tarjoamme myös SMT yhden luukun palvelua asiakkaalle.

9. Mitkä ovat tärkeimmät tekijät, jotka vaikuttavat piirilevyn hintaan?

Materiaali;

Pinnan viimeistely;

Teknologian vaikeus;

Erilaiset laatuksiteerit;

PCB-ominaisuudet;

Maksuehdot;

Eri valmistusmaat.

10. Mikä on PCB: n, PWB: n ja FPC: n määritelmä ja mikä on ero?

Piirilevy on lyhenne sanoista painettu piirilevy;

PWB on lyhenne sanoista Printed Wire Board, mikä tarkoittaa samaa kuin piirilevy;

FPC on lyhenne sanoista Flexible Printed Board.

11. Mitkä tekijät tulisi ottaa huomioon valittaessa materiaalia piirilevyille?

Seuraavat tekijät on otettava huomioon, kun valitsemme materiaalia PCB: lle:

Materiaalin Tg-arvon tulisi olla suurempi kuin käyttölämpötila;

Matalalla CTE-materiaalilla on hyvä lämpöstabiilisuus;

Hyvä lämmönkestävyys: Normaalisti PCB: n vaaditaan kestämään 250 °C vähintään 50 sekunnin ajan. Hyvä tasaisuus; Sähköisten ominaisuuksien huomioon ottamiseksi suuritaajuisissa piirilevyissä käytetään pienihäviöistä / suurta läpäisevyyttä sisältävää materiaalia; Polyimidilasilasisubstraatti, jota käytetään joustavaan PCB: hen; Metalliydintä käytetään, kun tuotteella on tiukat vaatimukset lämmön haihdutukselta.

12. Mitkä ovat O-Leadingin rigid-flex PCB: n edut?

O-Leadingin jäykällä joustavalla piirilevyllä on sekä FPC: n että PCB: n merkit, joten sitä voidaan käyttää joissakin erikoistuotteissa. Osa on joustava, kun taas toinen osa jäykkä, se voi säästää tuotteen sisätilaa, vähentää tuotteen määrää ja parantaa suorituskykyä.

13. Kuinka impedanssi lasketaan?

Impedanssinhallintajärjestelmä tehdään käyttämällä joitain testikuponkeja, SI6000 soft ja POLAR INSTRUMENTSIN CITS 500s -laitteita.

Laite mittaa impedanssin edustavalla radan kokoonpanokupongilla, jonka asiakas on antanut meille määritetyn arvon ja toleranssin.